

Q Siren
MODELS Q2B-012PNSD, Q2B-012NNSD
AND Q2B-012PSD, SERIES D

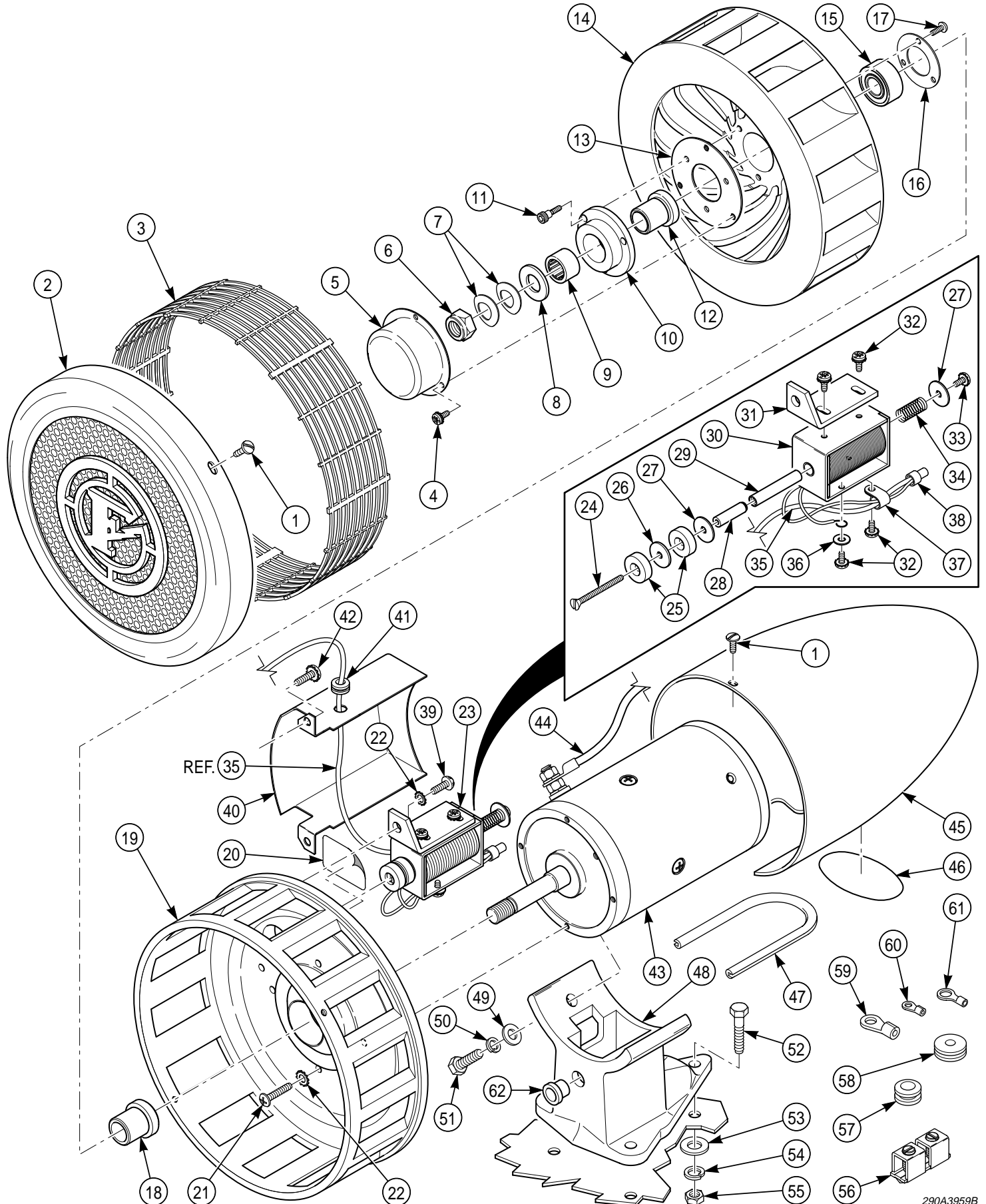

Q Siren

Models Q2B-012PNSD, Q2B-012NNSD and Q2B-012PSD, Series D

PPL 0320
PARTS LIST

March 2002

Item No.	Description	Part No.	Q2B-012 PNSD	Q2B-012 NNSD	Q2B-012 PSD
1	Screw, Machine #8-32 x 3/16" Slotted Binding Head	Z7000A008-03	4	4	7
2	Front Grill Assembly	Z8280C076A	1	1	1
3	Guard, Stator	Z8280A016-0C	1	1	1
4	Screw, Machine #6-32 x 1/4" Ext. Sems Slotted Torx Pan Head	Z7006A006-04	3	3	3
5	Cap, Clutch	Z8427A011	1	1	1
	Kit, Q2B Rotor/Clutch (Includes Items 6 Thru 17)	Z8280065B-K	1	1	1
6	Nut, Hex Elastic Stop 9/16-18	Z7058A036A	1	1	1
7	Washer, Spring	Z7074A054A	2	2	2
8	Washer, Flat (.593 x 1.187 x .093)	Z7072A140A	1	1	1
	Clutch Assembly (Includes Items 9 And 10)	Z8280084A	1	1	1
9	DC Roller, Clutch		1	1	1
10	Clutch Flange		1	1	1
11	Screw, Shoulder #10-24	Z7000480A	3	3	3
12	Bushing, Clutch	Z8280083A	1	1	1
13	Disc Assembly, Clutch Cap	Z8427A016C	1	1	1
14	Rotor, 9 14 Port	Z8280D020L-02	1	1	1
15	Bearing, Ball	Z8126A017B	1	1	1
16	Retaining Ring, Bearing	Z8088A001B	1	1	1
17	Screw, Machine #10-24 x 3/8" Phillips Pan Head	Z7000442-06	3	3	3
18	Bushing, Spacer	Z8427A004	1	1	1
19	Stator, 14 Port	Z8280D078A	1	1	1
20	Label, Warning, Speaker	Z161267B	1	1	1
21	Screw, Machine #10-24 x 7/8" Phillips Pan Head	Z7000468-14	4	4	4
22	Lockwasher, #10 External Tooth	Z7075A031	5	5	5
23	Brake Assembly, 12V (Includes Items 24 Thru 38)	Z8280B003A-02	1	1	1
24	Screw, Machine #10-32 x 2" Slotted Flat Head	Z7000A230-32	1	1	1
25	Pad, Brake	ZH7148-0A	2	2	2
26	Washer, Brake Pad	ZH7149-0A	1	1	1
27	Washer, Flat (.193 x .750 x .046) Fiber	Z7072A143A	2	2	2
28	Plunger, End	Z8280A009	1	1	1
29	Plunger	Z8280A010	1	1	1
30	Soleniod, 12V	Z8280A007-01	1	1	1
31	Bracket, Solenoid	Z8280A006	1	1	1
32	Screw, Machine #6-32 x 1/4" Ext. Sems Slotted Torx Pan Head	Z7006A006-04	4	4	4
33	Screw, Machine #8-32 x 5/16" Int. Sems Phillips Pan Head	Z7006A031-05	1	1	1
34	Spring	Z8280A017	1	1	1
35	Wire, Cut 12 AWG; Red (24")		1	1	1
36	Washer, Flat #6	Z7072A004	1	1	1
37	Clamp, Wire	Z8240A072	1	1	1
38	Connector, Wire	Z140A259A	1	1	1
39	Screw, Machine #10-32 x 5/8" Phillips Round Head	Z7000A070-10	1	1	1
40	Cover, Brake	Z8209B009B	1	1	0
41	Grommet	Z8108A014	1	1	0
42	Screw, Machine #8-32 x 3/8" Ext. Sems Phillips Pan Head	Z7006A011-06	2	2	0
43	Motor, 12V	Z8280080B	1	1	1
44	Wire, Terminated 4 AWG; Red		1	1	1
45	Housing, Q2B - Polished	ZH5205-03	0	0	1
46	Nameplate, Q2B		1	1	1
47	Gasket, 9"	Z8240A107-05	0	0	1
48	Base, Pedestal	Z8280C077A	1	0	1
49	Washer, Flat 5/16"	Z7072A031	2	0	2
50	Lockwasher, Split 5/16"	Z7074A020	2	0	2
51	Screw, Cap 5/16-18 x 7/8" Hex Head	Z7002A005-14	2	0	2
	Kit, Installation (Includes Items 51 Thru 60)	Z8209A021B	1	1	1
52	Screw, Cap 5/16-18 x 1-1/2" Hex Head	Z7002A005-24	3	3	3
53	Washer, Flat 5/16"	Z7072A031	3	3	3
54	Lockwasher, Split 5/16"	Z7074A020	3	3	3
55	Nut, Hex 5/16-18 Double Chamfer	Z7057A027	3	3	3
56	Connector	Z8283A712	1	1	1
57	Grommet	Z8108A002	1	1	1
58	Grommet	Z8108A005	1	1	1
59	Lug, Terminal	Z506A004B	3	3	3
60	Lug, Terminal	Z506A001	1	1	1
61	Terminal, Ring	Z224A202A-07	1	1	1
62	Bushing, Snap	Z8459A028	1	0	0
	Kit, Q2B Foot Switch (Not Shown)	Q2FSK	1	1	1

DO NOT ORDER PARTS BY ITEM NUMBER.

Give model, description and part number.

When a part number is not supplied, the part is **NOT** available.

Refer to PARTS PRICE LIST (Part No. 1001) for prices of parts.

Federal Signal Corporation
2645 Federal Signal Drive
University Park, IL 60466

Printed in U.S.A.